

Evaluating Battery Drain

N6700 Series modular power supplies

N6700 Series Modular System Power Supplies

N6705C DC power analyzer

- 600 W, four slots N6781A source / measure units (SMUs) modules
- 2-quadrant SMU for battery drain analysis
- DC output up to 20 W

N6785A SMU

- 2-quadrant SMU for battery drain analysis
- DC output of up to 80 W

Software

Keysight BV9200B PathWave BenchVue advanced power control and analysis software



Evaluate the performance of your battery easily and accurately with the advanced capabilities of the N6700 Series modular system power supplies.

Combine the N6700 Series modular system power supplies with the BV9200B PathWave BenchVue advanced power control and analysis software to get real-time results.

Introduction

This application note explains how to use the advanced capabilities of the Keysight N6700 Series modular system power supplies with the Keysight BV9200B PathWave BenchVue advanced power control and analysis software to evaluate the performance of a battery quickly and accurately.

The Keysight N6781A and N6785A source/measure units (SMUs) analyze the battery drain of battery-powered devices to help you reduce test time and ensure product performance.

Use the N6781A SMU with a DC output up to 20 W for small portable devices such as smartphones and music players. The N6785A SMU with a DC output up to 80 W is suitable for larger portable devices such as tablets.

You can measure and analyze the short and long-term battery drain using the Keysight N6705C DC power analyzer and any of the N6700 Series SMUs with the BV9200B PathWave BenchVue advanced power control and analysis software. You can use the actual battery instead of a DC source to power battery-powered devices for real-time results.

Challenges Using Traditional Approaches

Traditional methods using current shunts and probes to measure battery drain made it challenging for users to meet the accuracy required for the wide dynamic range of the current. The measurement had to avoid influencing the resulting voltage drop on the shunt when powering a device from a low voltage battery.

Battery drain tests can run for hours to days. Additional challenges with traditional approaches include the logging and storage of the massive amount of data generated and the subsequent post-test analysis and display of results. This process typically requires considerable software development time and effort.

In comparison, the N6781A or N6785A configurations act as a zero-ohm shunt that does not contribute to any voltage drop that may affect results.

The BV92000B control and analysis software gives you long-term measurement acquisition with post-test result visualization and analysis tools.

Advantages of Measuring Battery Drain Performance

The process of evaluating and optimizing battery operating time enables you to:

- Validate the actual operating time to compare against the criteria value.
- Verify battery capacity and performance to correlate against the battery manufacturer's standard specifications.
- Evaluate peak and average current and power consumption of the device when powered by its battery to compare against expected values to optimize device performance.

Recommended Setup

Battery drain test

The N6780 Series SMUs in current ammeter measure mode becomes a zero-burden current measurement shunt. Figure 1 shows that the voltage drop will not be an issue. The N6781A and N6875A SMUs come with a seamless range-switching measurement feature known as **seamless measurement ranging technology**. As the current transitions from sleep level to active, the measurement ranging feature adjusts the measurement range dynamically to get the highest accuracy at each point in the current waveform.

You can also use the programmable output resistance feature to enable the N6780 SMUs to emulate the internal resistance of a battery accurately. The BV9200B PathWave BenchVue advanced power control and analysis software provides the platform to easily log, visualize, and analyze a large quantity of measurement data.

The N6780 Series SMUs have a **current measurement only** mode that sets the power supply to behave like a zero-ohm shunt. Figure 1 shows a connection to the battery output and the battery-powered device — the SMUs will emulate a zero-burden ammeter. The regulated voltage is zero volts where the remote sense lines connect.

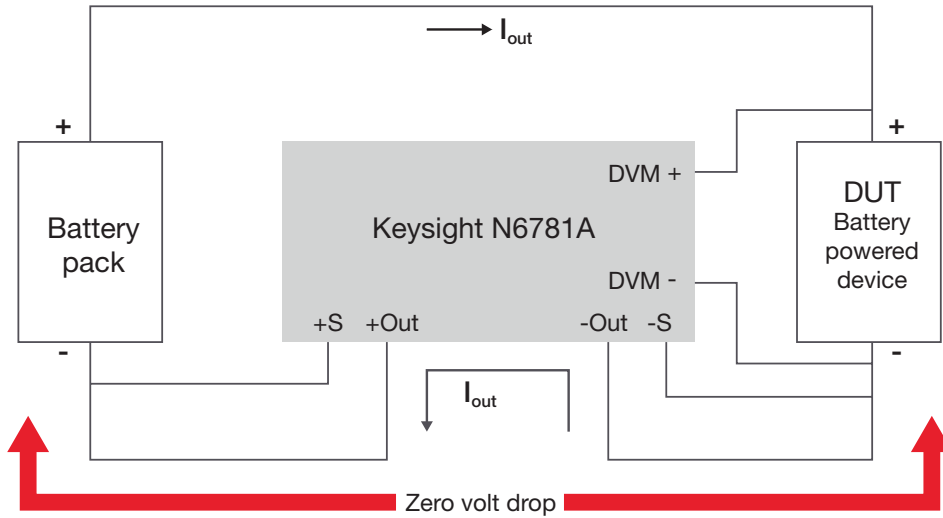

Figure 1. The recommended setup for measuring battery performance using the N6780 SMU. Transmitting the remote voltage eliminates the voltage drop in the wiring between the battery pack (-) and DUT (-). In this setup, the N6780 Series SMU modules are inside the N6705C DC power analyzer.

Figure 2 shows a typical configuration to measure battery drain performance. Select current measure as the emulating mode in the BV9200B source setting screen, as shown in Figure 3. The voltage priority mode sets to the default, and you can select the + / - current limits to the maximum allowable value. The result is zero-burden when the output setting is zero volts.



Figure 2. The setup for measuring battery drain performance using the N6781A or N6785A SMU installed as output 1 in an N6705 DC power analyzer

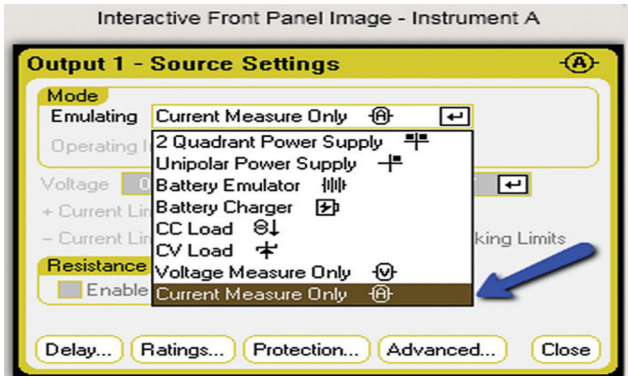

Figure 3. Source setting menu on the BV9200B BenchVue advanced power control and analysis software

How to use the auxiliary voltmeter

The N6780 Series SMUs have an auxiliary digital voltage meter (DVM) input that measures the battery voltage in battery drain applications. Measurements from the auxiliary voltmeter validate battery drain and performance. Figure 1 shows the DVM plus and DVM minus connections and the configuration of the auxiliary voltmeter. To enable auxiliary voltage measurements using the BV9200B BenchVue advanced power control and analysis software, expand the **Instrument Control** tab and select **Meter** then **Properties**.

Select the **Aux Voltage** option on the menu that appears, as shown in Figure 4. The auxiliary voltmeter will capture measurements with a digitization rate of up to 100 ksa/s simultaneously with the current.

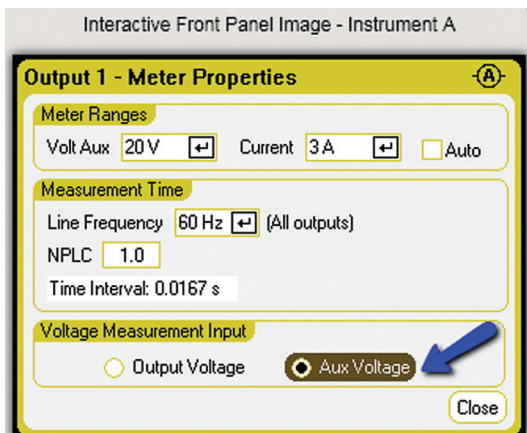

Figure 4. Example of auxiliary voltmeter setup

Using the scope mode

The BV9200B PathWave BenchVue advanced power control and analysis software includes scope mode to enable you to monitor the current drain. Easily control choices of voltage / current measurements, measurement ranges, and the scaling of the display using the graphical user interface in scope mode. You can also adjust the number of sample points per trace to a maximum of up to 256 K points for a single trace.

These features are also available from the front panel of the N6705C DC power analyzer using **Scope View**. Quickly start or stop the scope acquisition by pressing the **Play** button on the lower right-hand corner beneath the word **Scope**. You can bring up the markers to further analyze the track, as shown in Figure 5. Use the markers to focus on a specific time interval to extract information such as minimum, maximum, and average value.



Figure 5. Scope acquisition with markers

Using the data logging mode

The duration can be several hours or even days. Adjust the setting to run longer than the expected battery duration to ensure that you capture the entire cycle.

Depending on the setup, you can define the integration period for the data logging from 20 μ s to 60 seconds. The system generates a set of minimum, maximum, and average values logged during the integration period. The data log display plots the minimum, maximum, and average values in the same graph. Figure 6 is an example of a data log plot with the battery discharge results.

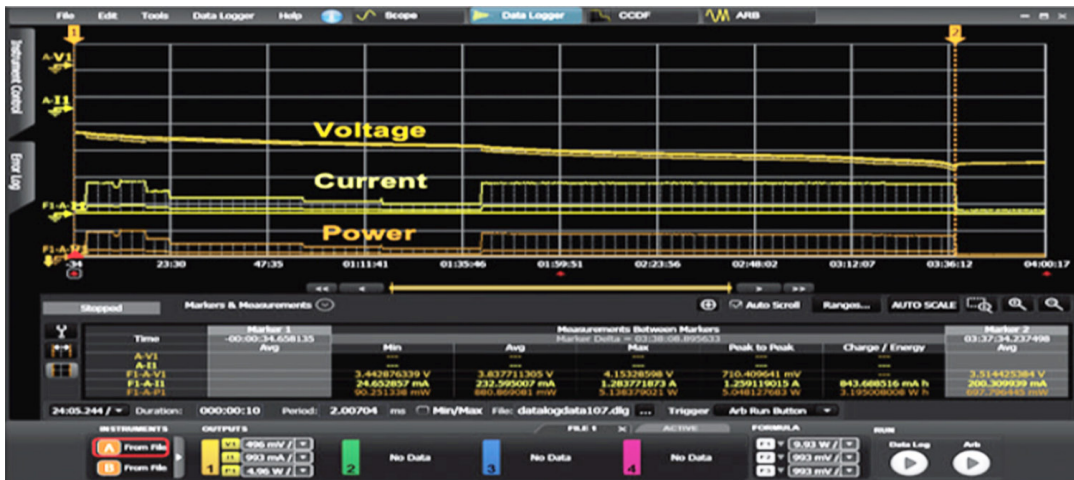

Figure 6. Example of actual battery drain with the data logging acquisition displaying voltage, current, and power

Figure 7 shows the markers available to use with data logging. Activate the vertical measurement markers and place them at the start and shutdown points. This process will set up the software to base its numerical calculations over the enclosed time interval rather than the entire display.

Measurements Between Markers				
Marker Delta = 00:00:03.965953 Freq = 252 mHz				
Min	Avg	Max	Peak to Peak	Charge / Energy
4.133285046 V	4.145959177 V	4.15293026 V	19.645214 mV	---
31.436499 mA	113.316957 mA	299.732208 mA	268.295709 mA	449.775565 mC
130.467156 mW	469.457483 mW	1.238878654 W	1.108411498 W	1.863362884 J

Figure 7. Measurements between markers in data logging mode

You can set the data logging function to measure the current and voltage reading from the auxiliary DVM. The stored data captured is in a binary format. There is an option to export the binary file into a .CSV file format. Figure 8 shows the complementary cumulative distribution function (CCDF) histogram display feature. It provides a concise display of short- and long-term battery drain measurements. Figure 8 also shows a distribution plot of the current amplitude versus its relative frequency of occurrence so you can quickly visualize and analyze large amounts of data.

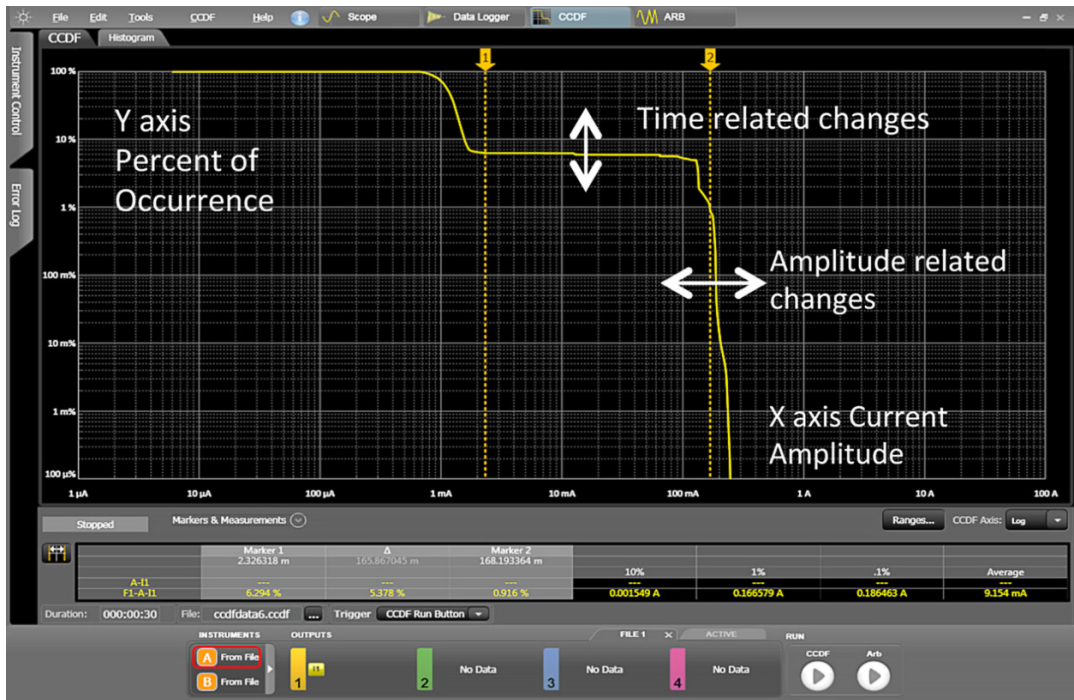

Figure 8. CCDF measurement reveals the key attributes of standby current in a smartphone

Summary

Using a battery instead of a DC power source when performing battery drain analysis gives you greater insight and accurate results into real-world operating time and battery capacity. The measurement ranging feature available on N6780 SMUs overcomes accuracy shortcomings of traditional approaches that use current transducers. This measurement feature dynamically adjusts the measurement range to allow the highest accuracy at each point in the battery run-down current waveform.

The auxiliary voltmeter, scope mode, and data logging modes are additional tools and features available on the N6781A and N6785A SMUs and N6705 power analyzer that will help you in evaluating battery run-time. You can control using the front panel of the N6781A and N6785A SMUs inside an N6705C DC power analyzer, or you can control it with the BV9200B PathWave BenchVue advanced power control and analysis software.

For more information, please visit:

N6700 Series system power supplies

BV9200 PathWave BenchVue advanced power control and analysis software

www.keysight.com/find/BV9200

N6781A / N6785A

www.keysight.com/sg/en/products/dc-power-supplies.

Learn more at: www.keysight.com

For more information on Keysight Technologies' products, applications or services, please contact your local Keysight office. The complete list is available at: www.keysight.com/find/contactus

