

**FOUR BEST PRACTICES FOR**

# Precise Millimeter-Wave Measurements

# Contents

## Four Best Practices for Precise Millimeter-Wave Measurements

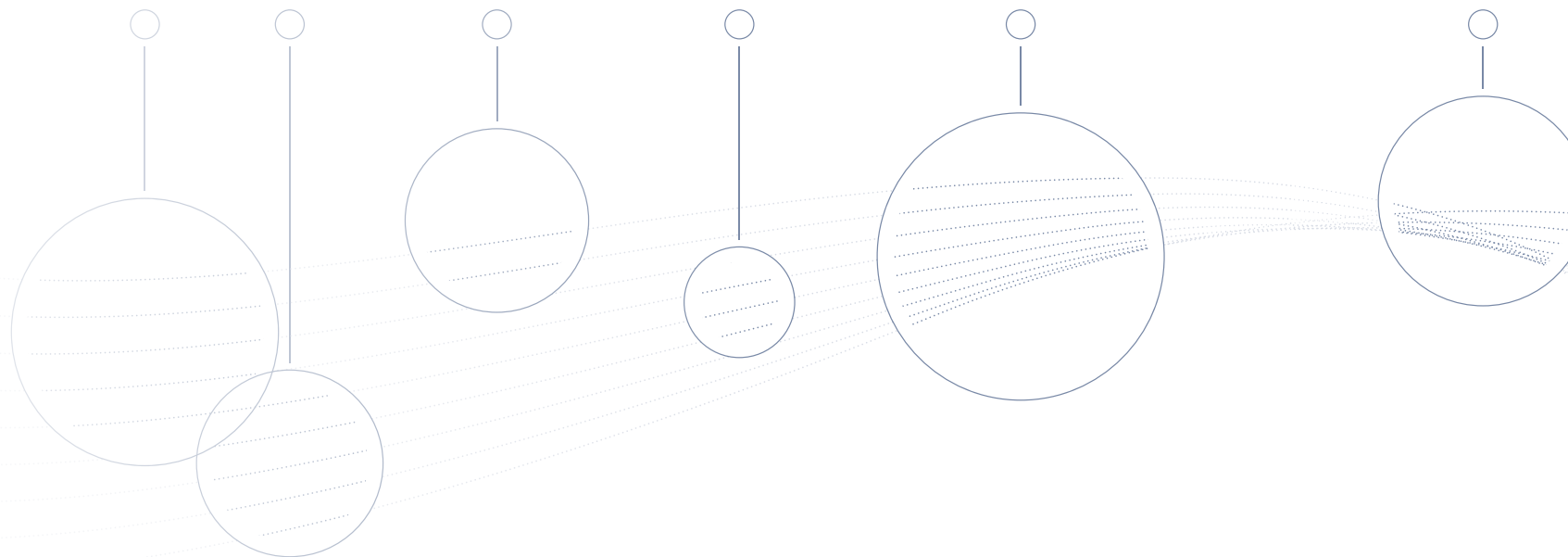

# Introduction

Millimeter-Wave frequency measurements require precision and care. Fortunately, the engineering challenges have become a little less daunting as more millimeter test equipment has become available. Signal analyzers have now increased direct coverage in coax to 110 GHz. This provides low noise, good accuracy, and wide bandwidth to allow engineers to focus on their designs and measurement results instead of pulling together multi-part test solutions where calibration and repeatability may be in question.

However, all this hard-won performance can be compromised if you miss even one of the fundamental practices for good measurements at these very high frequencies. The millimeter range is generally defined as 30–300 GHz, with wavelengths down to 1 mm, and these tiny wavelengths are the heart of many problems and challenges.

Connectors are a good place to start because they exemplify so many of the ways that millimeter measurements can challenge you. Figure 1 is a close-up of female and male 1 mm connectors, which are mode-free to more than 110 GHz.

The small size and precise geometry of millimeter connectors and cables demand special machining and fabrication. They are necessarily somewhat expensive and inescapably more delicate as frequencies increase and dimensions decrease. Not all connector types at these frequency ranges can intermate. Even when mechanical compatibility is possible, all intermating and even same-connector mating still produces impedance problems that should be avoided wherever possible.

Let's discuss four best practices when you are making millimeter-Wave measurements.

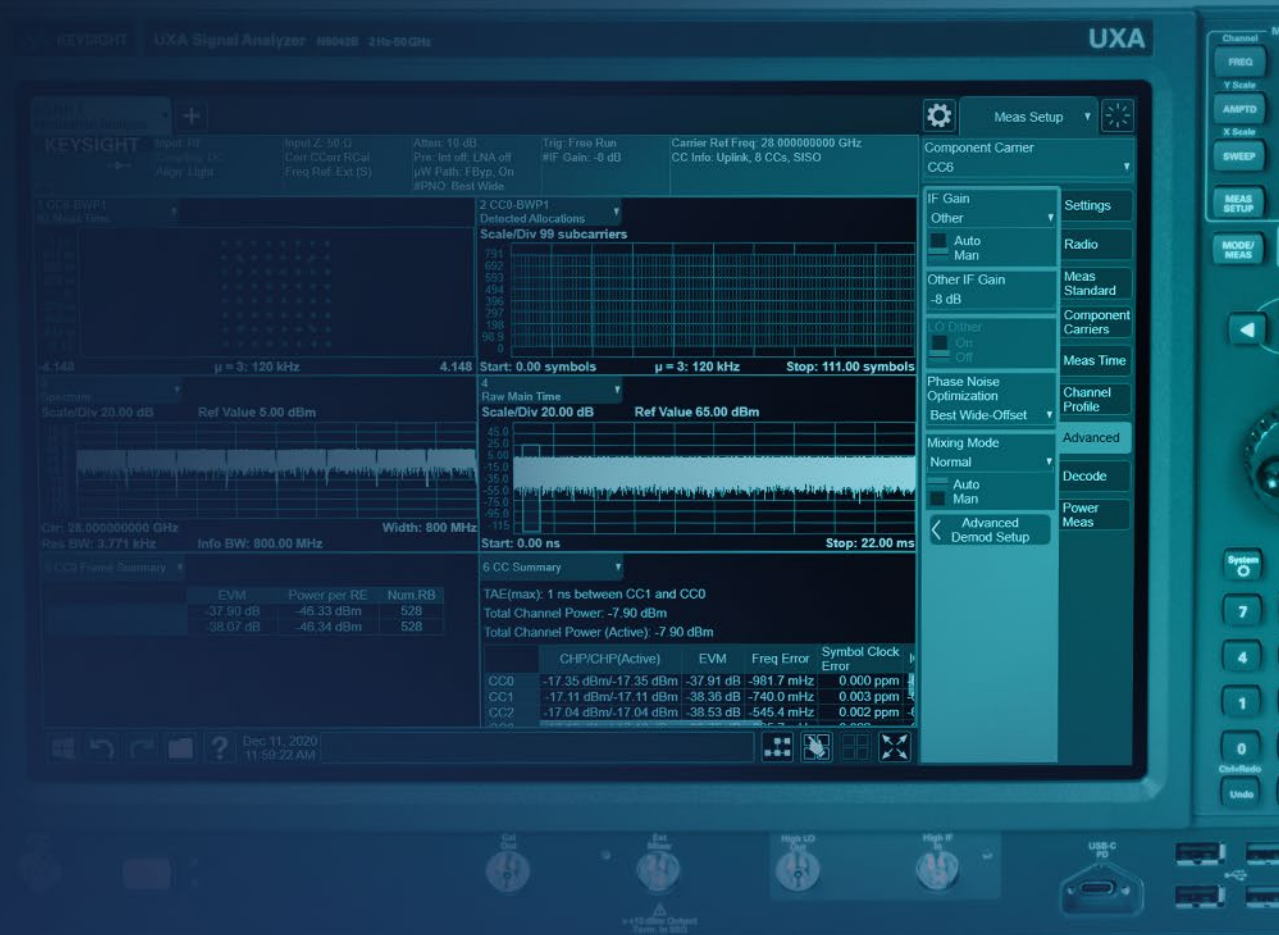

Figure 1. Female and male 1 mm connectors. The center pin in the jack on the right is only one-quarter of 1 mm in diameter.



## CHAPTER 1

# Connection to the Signal Analyzer



## CHAPTER 1

# Connection to the Signal Analyzer

Perhaps the most important connection is the one at the front panel of the test equipment. Despite their delicacy, male connectors are better than the alternative at millimeter frequencies. The usual practice is to attach a female-to-female “connector saver” at the instrument, but this choice is complicated by the fact that impedance problems and loss through cables and connectors or adapters also get worse as frequencies increase. In some cases, it’s worth the cost and trouble of acquiring custom cabling with correct gender at each end, especially considering how precious power and performance are at these frequencies. Custom cabling also allows the cables to be as short as possible. Indeed, one tactic that is sometimes overlooked is to simply move the DUT and instrument as close to each other as practical.

### LEARN MORE



Catalog: *Signal Analysis Solutions*



Figure 2. While the typical front-panel connector is female, the gender is often reversed for equipment covering millimeter frequencies (30 GHz to 300 GHz). The male connector offers some degree of protection from several types of damage.



Figure 3. “Connector savers” are coaxial adapters placed between instrument front-panel connectors and cables or DUTs. They can be easily replaced if they are damaged or become worn. **Adapters and connectors** can be found on [www.keysight.com](http://www.keysight.com).





## CHAPTER 2

# Connector Care

---



## CHAPTER 2

# Connector Care

Figure 1 suggests another area of best practices: connector care. These connectors do not appear obviously damaged or displaced, but some contamination is clearly present. Because of their tiny dimensions, **special cleaning materials and techniques** are needed for microwave and millimeter connectors. **Connector gauges** are also important to ensure that mechanical dimensions are within the tight tolerances that provide a reasonable impedance match.

### LEARN MORE



Application Note: *Handling Precautions for Modules, Accessories, and Test Instruments*

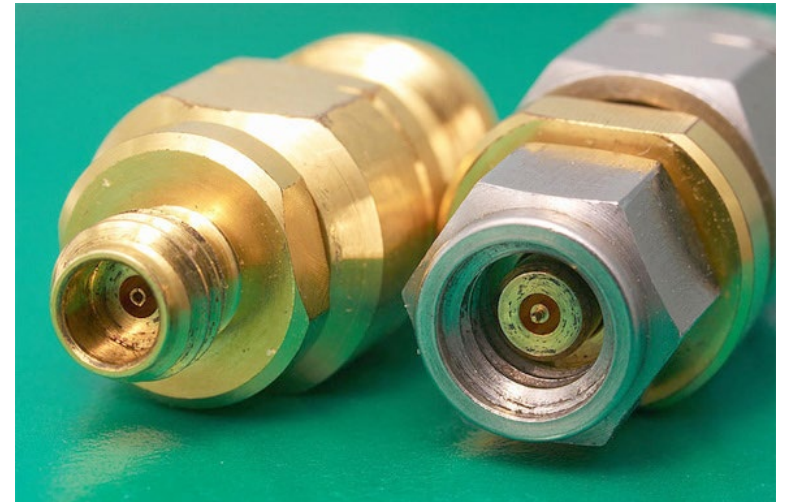

Figure 1. Female and male 1 mm connectors. The center pin in the jack on the right is only one-quarter of 1 mm in diameter.

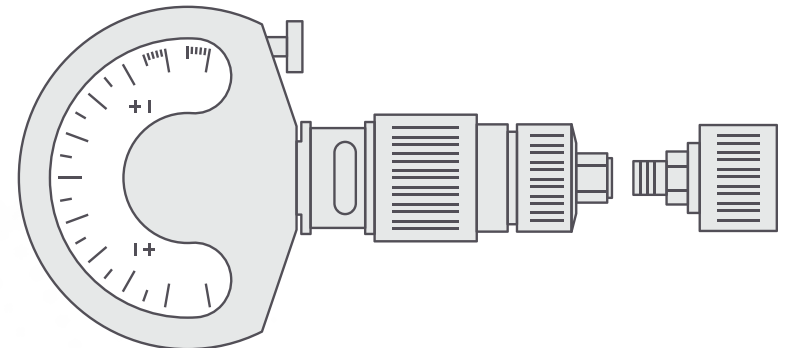

Figure 4. Connector gauges are important to ensure that mechanical dimensions are within the tight tolerances that provide a reasonable impedance match.





CHAPTER 3

# Connector Torque

---





## CHAPTER 3

# Connector Torque

Proper connector torque is another fundamental for good millimeter connections. Consistent torque and proper use of a torque wrench are important approaches to minimizing impedance mismatch and loss. The mechanical essentials and ways to avoid damaging these connectors are important.

The power of wrenches must be used carefully because you can't feel forces through them the way you do with your fingers. The potential for over-straining something is also greater when multiple or longer adapters are used or when devices are connected directly without cables that relieve bending stress. The diagram below describes one example: "wrench-lift stress."

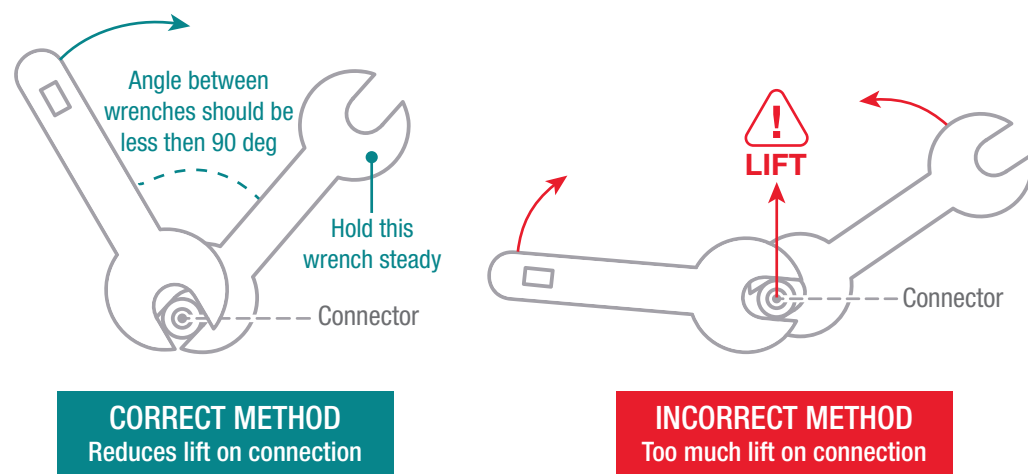

Figure 5. Using the appropriate wrenches to tighten or loosen connectors is good practice but they can cause wrench-lift stress and bend connectors if used the wrong way. Maintaining a small angle between the two wrenches during assembly and disassembly will avoid the problem.

## Torque Settings

Connector types	Frequency range (up to)	Torque setting	Wrench part number
1.0 mm	110 GHz	4 in-lb (45 N-cm)	8710-2079
1.85 mm	70 GHz	8 in-lb (90 N-cm)	8710-1765
2.4 mm	50 GHz	8 in-lb (90 N-cm)	8710-1765
NMD <sup>1</sup> 2.4 mm	50 GHz	8 in-lb (90 N-cm)	8710-1764
2.92 mm	40 GHz	8 in-lb (90 N-cm)	8710-1765
3.5 mm	34 GHz	8 in-lb (90 N-cm)	8710-1765
NMD <sup>1</sup> 3.5 mm	34 GHz	8 in-lb (90 N-cm)	8710-1764
SMA	24 GHz	5 in-lb (56 N-cm)	8710-1582

1. The NMD connector uses a larger outer mechanical interface to provide a stable connection at the front panel. They typically connect with the VNA test port connectors as connector savers.





## CHAPTER 4

# External Mixing



## CHAPTER 4

# External Mixing

Given the connection losses in coax and the sometimes cumbersome physical implications of waveguide, you may want to consider external mixers. Keysight's **Smart Harmonic Mixers** cover 50-110 GHz and make this approach much more convenient and accurate than previous mixers. They allow you to create a remote test head, placing the measurement plane right at the DUT. While they lack the IF bandwidth of a signal analyzer with continuous, direct frequency coverage, they do allow lower frequency signal analyzers to cover these high frequencies.

Keysight's V3050A advanced external frequency extender integrates a preselector and an RF switch into a high-dynamic-range mixer with the seamless operation interface of the Keysight **N9042B UXA X-Series signal analyzer**. This solution enables unbanded and preselected swept power spectrum from 2 Hz to 110 GHz without managing band breaks and images.

For the vector mode, the RF bandwidth is up to 4 GHz. You can also get the most out of your measurement and see your device's real performance by removing magnitude and phase errors in the measurement setups up to 110 GHz with the Keysight **U9361 RCal receiver calibrator**.

### LEARN MORE



White Paper: *Tackling Millimeter-Wave Signal Analysis Challenges*



EXTERNAL MIXING

# Summary

These fundamentals are straightforward practices to implement. They will help you pass the tests you will face as your designs take you well into millimeter territory.

## LEARN MORE



Application Note: *Four Hints for Better Millimeter-Wave Signal Analysis*

